

Hidden Helpers

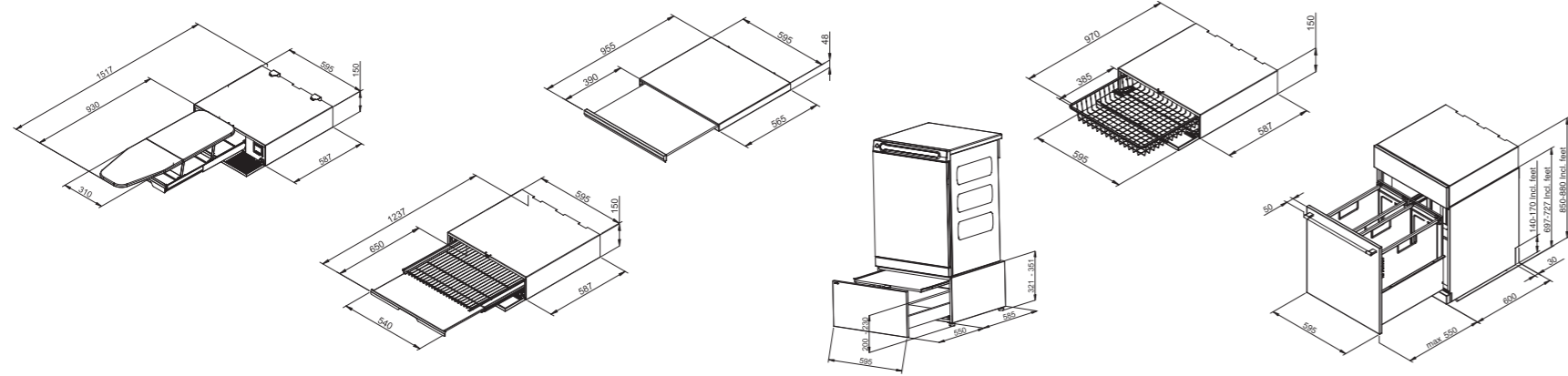

Model	HI115T/Hi215T* Pull out Ironing Board	HDB115T/HDB215T* /HDB215S* Laundry care double	HSS105T/HSS205T /HSS205B* Laundry care single	HPSS32S/HPSS32S* Pedestal Drawer	HB1155T/HB215S* Laundry care basket	HSO570T* Sorting unit
Colour	tt	tt/ss	tt/bl/ss	ss	tt/ss	tt
Unopened dimensions						
Height (mm)	150	150	48	321-351	150	697-727
Width (mm)	595	595	595	595	595	595
Depth (mm)	587	587	565	585	587	600
Weight (kg)	21	24.5	10	26.8	14.5	33.5
Opened dimensions						
Height (mm)	90	80	25	200-230	150	697-727
Width (mm)	310	540	565	520	595	595
Depth (mm)	930	650	390	550	385	550
Work Height (mm)	1042-1072	625-955	871	300	967-997	608-638
Features:						
Push/pull opening	•	•		•	•	
While in use, place for iron	•					
Adjustable telescopic rails	•	•				
Tipguard	•	•			•	
Removable wire basket		•			•	
Telescopic pull out shelf		•	•	•		
Laundry bags						
Maximum load (kg)	10	10	10	15	5	12
Volume (l)				77.5		2x50
Shelf surface	Steel	Steel		Steel	Steel	Steel
Ironing board fabric	Silver		Laminate			
Technical specifications						
Maximum connected power (w)	2300					
Electrical cord length (mm)	1600					

tt - titanium
ss - stainless steel
bl - black

*Circle series/integrated model codes
HA15W Arm for ironing board - matches all
HL105T Laundry Care List, Titanium - matches line series
HL205T Laundry Care List, Titanium - matches integrated and circle series

Rotary Iron

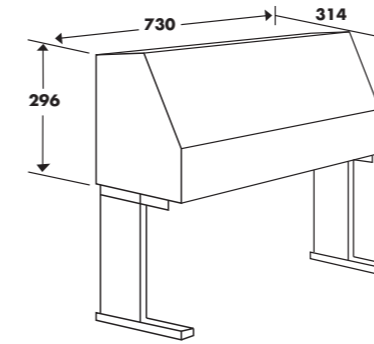

Model	C1700
Type	Cold iron
Free standing	•
Colour	wh
Dimensions	
Height (mm)	296
Width (mm)	730
Depth (mm)	314
Roller width (mm)	598
Roller diameter (mm)	120
Weight (kg)	20
User Interface	
Knobs no.	0
Settings	1
Operating data	
Roller pressure (kN)	3.4-4.0
Feed rate (rpm)	9.5
Wheels under frame	
Finger guard	
Temperature guard	
Optional accessory: stand with basket	
Technical Data	
Rated effect (w)	90
Rated voltage (v)	230
Frequency (Hz)	50
Fuse (a)	10
Electrical cord (mm)	1900

tt - titanium
ss - stainless steel
bl - black

Drying Cabinets

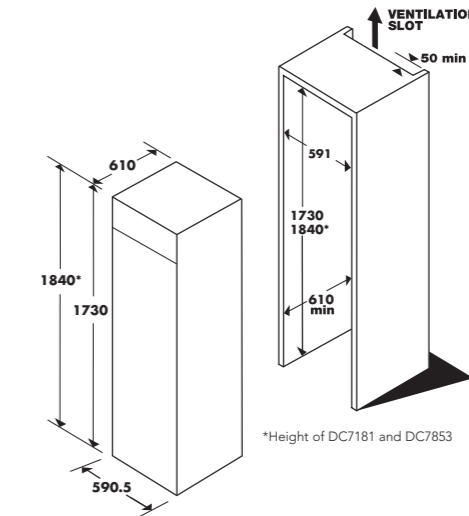

Laundry note: The drying cabinet should be vented into an extraction duct if surrounded by cabinetry, or situated in a small room. Dimensional specifications are provided for planning purposes only. For complete details see the installation instructions that accompany each product before selecting cabinetry, making cut-outs or beginning installation.

*Height of DC7181 and DC7853

Model	DC7171	DC7181*	DC7853*
Interface	Circle Series	Circle Series	Line Series
Free standing/Can be built in	•/•	•/•	•/•
Colour	ss/tt	ss/tt	ss/tt
Dimensions			
Height (mm)	1730	1840	1840
Width (mm)	590.5	590.5	590.5
Depth (mm)	610	610	610
Weight (kg)	60	60	60
User Interface			
Knobs	2	2	2
Timer (hrs)	4	4	4
Drying Programmes			
Normal temperature	•	•	•
Low temperature	•	•	•
Air fluff	•	•	•
Operating data			
Energy consumption - normal temperature (kWh)	0.7	0.8	0.8
Drying time - normal temperature (min)	120	120	120
Capacity (kg)	3.5	3.5	3.5
Hanging length, clothesline equivalent (m)	16	16	16
Dehumidification capacity (g/min)	17.5	17.5	17.5
Internal air exchange rate (m3/h)	200	200	200
Overheat protection	•	•	•
Technical Data			
Motor rating (w)	35	35	35
Element output (w)	1500	1500	1500
Rated voltage (v)	230	230	230
Frequency (Hz)	50	50	50
Fuse (a)	10	10	10
Electrical cord (mm)	2000	2000	2000
Venting hose length (mm)	1000	1000	1000
Noise Level db (A)	58	58	58

SPECIFICATIONS

Super Premium LRC Washers

Model	MWA 0720IIA Integrated	MWA 0718FIB Free standing	MWA 0716FIC Free standing	MWA 0714FIC Free standing	MWA 0714FBC Free standing
Fitted door	Ready to accept integrated door	Not fitted	Yes	Yes	Yes
Front door/lid opens	Side	Side	Down	ss/tt	bl
Colour	See options	ss/tt	ss/tt	ss/tt	bl
Dimensions					
Height (mm)	850	850	850	850	850
Width (mm)	595	595	595	595	595
Depth with door (mm)	1165	1165	1080	585	585
Height adjustment (mm)	30	30	30	30	30
Weight with door (kg)	78	78	78	78	78
User Interface					
Knob	•	•	•	•	•
Microprocessor controlled/timer	•	•	•	•	•
Display	Line Series+	Line Series	Circle Series	Circle Series	Circle Series
Wash Programmes					
Auto wash	•	•	•	•	•
Stain programme	optional	optional	•	•	•
Time programme	•	•	•	•	•
Heavy wash	•	•	•	•	•
Normal white/Colour wash	•	•	•	•	•
White quick	•	•	•	•	•
Colour quick	•	•	•	•	•
Super quick	•	•	•	•	•
Synthetic	•	•	•	•	•
Wool/Hand wash	•	•	•	•	•
Temperature selection	•	•	•	•	•
Max spin speed (rpm)	2000	1800	1600	1400	1400
Variable spin speed	•	•	•	•	•
Super rinse	•	•	•	•	•
Delayed start (h)	0.5-24	1-24	1-24	1-24	1-24
Super wash	•	•	•	•	•
Pre-wash	•	•	•	•	•
Additional options	•	•	•	•	•
Operating Data					
Capacity (maximum kg)	7	7	7	7	7
Energy efficiency rating	A+	A+	A+	A+	A+
Washing performance rating	A	A	A	A	A
Spin drying rating	A	A	A	B	B
Energy consumption (kWh/kg)	0.17	0.17	0.17	0.17	0.17
Energy consumption (kWh/cycle)	1.19	1.19	1.19	1.19	1.19
Water consumption 3 rinses (litres/cycle)	59	59	59	59	59
Time programme (mins/cycle)	155	155	155	155	155
Estimated annual consumption for a 4 person household (kWh)	238	238	238	238	238
Estimated annual consumption for a 4 person household (litres)	11800	11800	11800	11800	11800
Noise with door db(A) re 1pW	46/76	46/76 no door	49/78	49/76	49/76
Technical data					
Stainless Steel inner/outer drum	•/•	•/•	•/•	•/•	•/•
Balance control	•	•	•	•	•
Rated effect (kW)	2.2	2.2	2.2	2.2	2.2
Rated voltage (v)	230	230	230	230	230
Frequency (Hz)	50	50	50	50	50
Fuse (a)	10	10	10	10	10
Electrical cord, length (mm)	2100	2100	2100	2100	2100
Water connection, press-proof hose and fitting (inch)	3/4	3/4	3/4	3/4	3/4
Inlet hose length (mm)	1500	1500	1500	1500	1500
Drain hose length (mm)	1700	1700	1700	1700	1700
Water outlet via hose/max pumping level (mm)	900	900	900	900	900
Cold fill only	•	•	•	•	•

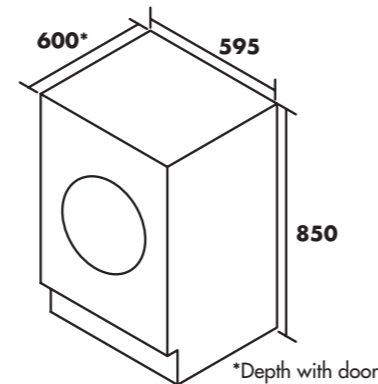
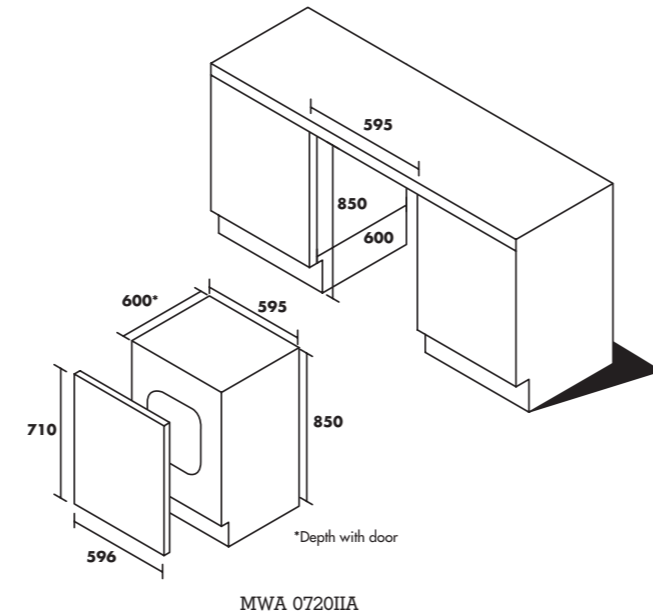

Super Premium LRC Dryers

Model	MTD 07SCIIA Integrated	MTD 07SCFIB Free standing	MTD 07SCFIC Free standing	MTD 07SCFBC Free standing
Fitted door	Ready to accept integrated door	Yes	Yes	Yes
Door/lid opens. R/L= right or left	r/l	r/l	r/l	r/l
Colour	ss/tt	ss/tt	ss/tt	bl
Dimensions				
Height (mm)	850	850	850	850
Width/depth (mm)	595	595	595	595
Depth with door open (mm)	1165	1165	1170	1170
Height adjustment (mm)	30	30	30	30
Weight (kg)	47	47	47	47
User Interface				
Knob	•	•	•	•
Microprocessor controlled/Timer	•	•	•	•
Display	Line Series+	Line Series	Circle Series	Circle Series
Drying programmes				
Auto Extra Dry	•	•	•	•
Auto Dry	•	•	•	•
Auto Normal Dry	•	•	•	•
Auto Iron Dry	•	•	•	•
Jeans	•	•	•	•
Synthetics	•	•	•	•
Time programme (mm)	5-180	5-180	60	60
Airing programme (mm)	5-180	5-180	60	60
Drying Options				
Anti-crease programme (min)	60/120/180	120	120	120
Temperature option:low/normal	•	•	•	•
Quick cool down (3 min)	•	•	•	•
Buzzer	•	•	•	•
Delayed start (h)	0.5-24	1-24	1-24	1-24
Feature				
Internal light	•	•	•	•
Operating Data (10A Connection)				
Capacity (kg)	7	7	7	7
Energy efficiency rating on a scale of A to G	B	B	C	C
DRY COTTON				
Energy Consumption (kWh/kg)	0.64	0.64	0.73	0.73
Energy Consumption (kWh/cycle)	4.48	4.48	5.1	5.1
Time (mins/cycle)	135	135	140	140
DRY IRON				
Energy Consumption (kWh/kg)	0.59	0.59	0.66	0.66
Energy Consumption (kWh/cycle)	4.13	4.13	4.6	4.6
Time (mins/cycle)	120	120	120	120
EASY CARE				
Energy Consumption (kWh/kg)	0.46	0.46	0.53	0.53
Energy Consumption (kWh/cycle)	1.61	1.61	1.9	1.9
Time (mins/cycle)	50	50	50	50
Estimated annual consumption for a four person household (kWh)	330	330	374	374
Noise db(A) re 1pW	66	66	68	68
Technical Data				
Stainless Steel Drum	•	•	•	•
Power rating	2.2	2.2	2.2	2.2
Rated voltage (v)	230	230	230	230
Frequency (Hz)	50	50	50	50
Fuse (a)	10	10	10	10/16
Electrical cord, length (mm)	2100	2100	2100	2100
Drain hose length (mm)	2000	2000	2000	2000

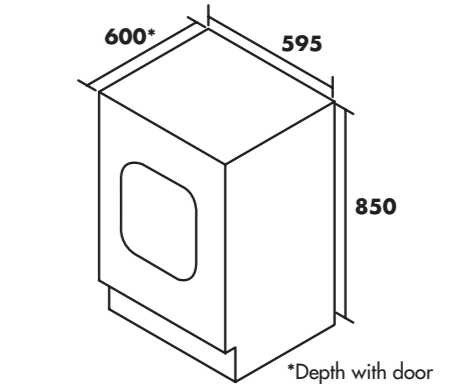
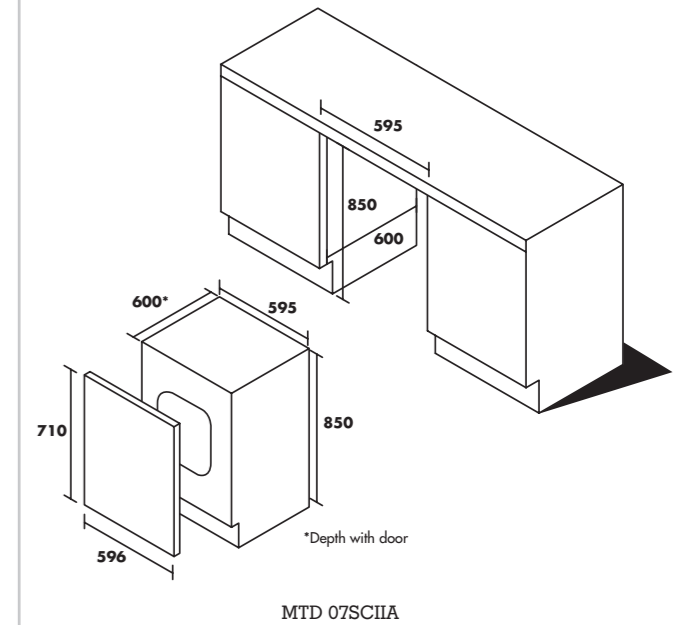

tt - titanium
ss - stainless steel
bl - black

SPECIFICATIONS

Premium 60 Series Washing

Model	Premuim Series 60 Washing		Super Capacity Washing
	MWA 0814FWN Free standing	MWA 0814FBN Free standing	MWA 1112FBS Free standing
Colour	White	Black	Black
Dimensions			
Appliance height (mm)	850	850	965
Appliance width (mm)	600	600	686
Appliance depth (mm)	600	600	785
Appliance depth with door open (mm)			
Weight (kg)	73	73	105.2
Performance			
Energy rating	A+	A+	A
Washing performance	A	A	A
Spinning efficiency	A	A	B
Water consumption (litres) based on 60 degree wash	64	64	86
Energy consumption (kWh/cycle)	1.36	1.36	1.87
Noise level wash/spin db(A)			56/74
Specification			
Load capacity (kg)	8	8	11
Spin speed (rpm)	1400	1400	1200
No. of programmes	14	14	15
Cottons	•	•	•
Colours	•	•	•
Daily load	•	•	•
Large load	•	•	•
Delicates	•	•	•
Synthetics	•	•	•
Wool	•	•	•
Hand wash	•	•	•
Quick wash	•	•	•
Variable temperature	•	•	•
Rinse hold	•	•	•
Super rinse	•	•	•
Spin speed reduction	•	•	•
Extra rinse	•	•	•
Eco steam	•	•	•
Easy iron	•	•	•
Rapid plus	•	•	•
Delay start	•	•	•
Intellisense®	•	•	•
Microban® dispenser draw	•	•	•

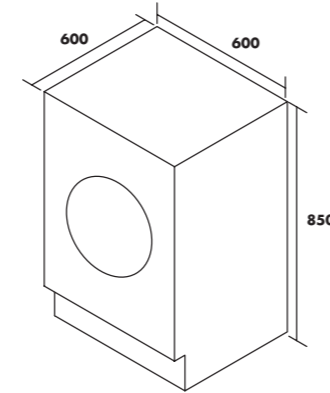

MWA 0814FWN/MWA 0814FBN

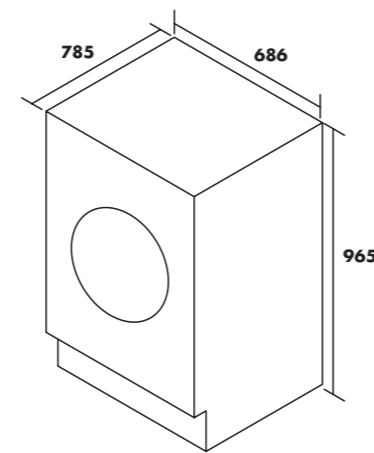

MWA 1112FBS

US Style Laundry

Model	Washing	Drying
	3RMTW4905TW	3RMED4905TW
Colour	White	White
Dimensions		
Adjustment Feet	4	4
Height (mm) including control panel	1092	1092
Width (mm)	686	686
Depth (mm)	743	743
Appliance Height with Door Open (mm)	1300	
Specification		
Loading Method	Top loading	Front loading
Capacity (kg)	8.2	10
No. of programmes	5	7
Energy Rating/Consumption (kWh)	G/0.63	C/6.50
Drying System		Vented
Automatic Sensor Drying		•
Features		
Spin Speed (rpm)	650	
Casual	•	
Delicates	•	
Hand washable	•	
Normal	•	
Extra rinse	•	
Temperature selector	•	
Water level selector	•	
Timed dry programmes		•
Air fluff		•
Freshen up		•
Front mounted lint screen		•
1000mm/2ft vent hose		•
Rear air venting		•
100mm metal duct		•
Connect required		•

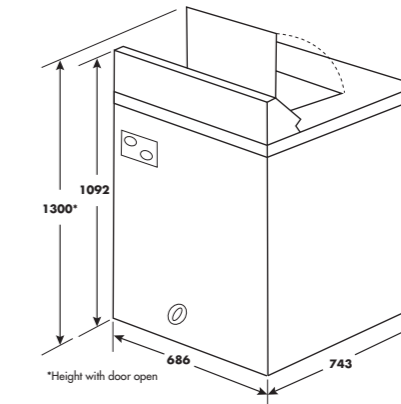

3RMTW4905TW

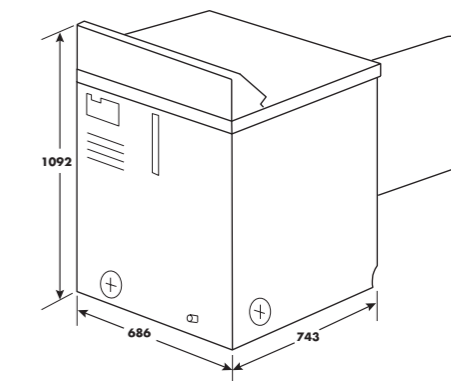

3RMED4905TW

* American washing machines requires equal water pressure in both the hot and cold inlet hoses. The water pressure must be between 30 and 120psi. The American tumble dryer requires a 30 amp electrical connection and should be vented into rigid metal ducting due to high temperatures.

We at Maytag are constantly working to make our products better. We therefore reserve the right to change designs or specifications without any notice. E&OE.

SPECIFICATIONS

Dishwashing

Model	XXL ¹⁷			
	MDW 17ITN Fully Integrated	MDW 17FTI Free standing	MDW 15ITN Fully Integrated	MDW 15FTI Free standing
Dimensions				
Height without/worktop	860/890	860/890	860/890	860/890
Width, built in/free standing (mm)	596/600	596/600	596/600	596/600
Depth (mm)	570	570	570	570
Depth with door open (mm)	1230	1230	1230	1230
Height adjustment (mm)	50	50	50	50
Maximum plate size (mm)	390	390	390	390
Total loading height (mm)	580	580	580	580
Weight built in, without/with softener (kg)	53/56	53/56	53/56	53/56
Wash programme				
Auto wash	•	•	•	•
Daily wash	•	•	•	•
Time wash	•	•	•	•
Quick wash	•	•	•	•
Heavy wash	•	•	•	•
Normal wash	•	•	•	•
Mix wash	•	•	•	•
1/2 Load - Upper rack	•	•	•	•
1/2 Load - Lower rack	•	•	•	•
Delicate/Glass wash	•	•	•	•
Rinse and hold	•	•	•	•
Rinse and dry	•	•	•	•
Turbo dry	•	•	•	•
Programming Options				
Delayed start	•	•	•	•
1/2 Load	•	•	•	•
Temperature	D	D	B	B
Drying optional	•	•	•	•
SuperRinse™	•	•	•	•
CoolTouch™	•	•	•	•
Time saver	•	•	•	•
Time set	•	•	•	•
Operating Data				
Energy efficiency rating A-G	A	A	A	A
Energy consumption (15c inlet) kWh	1.05	1.05	1.05	1.05
Cleaning performance rating A-G	A	A	A	A
Drying performance rating A-G	A	A	A	A
Standard place settings ¹	17	17	15	15
Water consumption with/without softener (litres)	9.9	9.9	11	11
Programme time (min)	170	170	170	170
Estimated annual consumption (220 cycles) kWh	229	229	231	231
Sound power level db(A)	45	45	47	47
Water connection				
Pex hose connection dimensions (inch)	3/4	3/4	3/4	3/4
Required inlet water pressure (Mpa)	0.03-7	0.03-7	0.03-7	0.03-7
Inlet hose length (mm)	1650	1650	1650	1650
Drain hose length (mm)	1600	1600	1600	1600
Softener: 0.7 dH/No. of adj.lev.	10	10	10	10
Electrical Specification				
Rated voltage (v)	230	230	230	230
Frequency (Hz)	50/60	50/60	50/60	50/60
Power rating (kW)	1.7	1.7	1.7	1.7
Fuse (a)	10	10	10	10
Cleaning				
Spray zones	10	10	8	8
Power zones	3	3	3	3

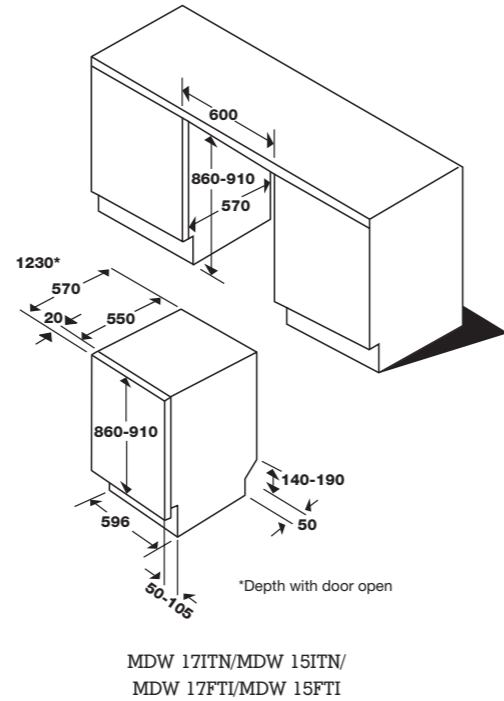

Refrigeration

Model	New Trim Kit Model	Trilogy	Customised				Core			
	MSS 20 TBB14 Fitted trim kit/ Gloss Black panels fitted	SOV028TB Trilogy 3 door	MSS 20 CGII4 Glass line doors/ SS cabinet	MSS 20 CGSI4 Glass line doors/ silver cabinet	MSS 20 CIII4 SS Doors/ SS cabinet	MSS 20 CISI4 SS Doors/ silver cabinet	MSS 20 FISI4 Finger proof SS flat doors with contoured edge/ silver cabinet	MSS 20 FSSI4 Silver flat doors with contoured edge/black cabinet	MSS 20 FBBI3 Black flat door with contoured edge/silver cabinet	MSS 20 FBBI3 Black flat door with contoured edge/black cabinet
Dimensions										
Cabinet height with top box (mm)			1805	1805	1805	1805				
Cabinet height with hinge (mm)	1774	1796					1772	1772	1772	1772
Cabinet width (mm)	902	915	906	906	906	906	902	902	902	902
Cabinet depth without door (mm)	600	599	602	602	602	602	600	600	600	600
Cabinet depth with door (mm)	748	675	748	748	748	748	743	743	743	743
Depth with door open to 90 degrees (mm)	1130		1130	1130	1130	1130	1135	1135	1135	1135
Distance from side wall to allow full access (mm)*	355	400	355	355	355	355	375	375	375	375
Approximate shipping weight (kgs)	146	168	146	146	146	146	109.5	109.5	109.5	109.5
System controls										
Control system	Electronic	Electronic	Electronic	Electronic	Electronic	Electronic	Electronic	Electronic	Electronic	Electronic
Ice and water dispenser	•		•	•	•	•	•	•	•	•
Microban® filter	•		•	•	•	•	•	•	•	•
Water filter	•		•	•	•	•	•	•	•	•
Water filter indicator	•		•	•	•	•	•	•	•	•
Chilled water	•		•	•	•	•	•	•	•	•
Cubed ice	•		•	•	•	•	•	•	•	•
Crushed ice	•		•	•	•	•	•	•	•	•
Dispenser light	•		•	•	•	•	•	•	•	•
In door ice dispenser	•		•	•	•	•	•	•	•	•
Intellisense® technology	•		•	•	•	•	•	•	•	•
In door crisper	•		•	•	•	•	•	•	•	•
Performance and capacity										
Feature level type	Best	Best	Best	Best	Best	Best	Better	Good	Better	Good
Total Capacity gross litres	540		540	540	540	540	540	540	540	540
Total Capacity net litres	505		505	505	505	505	505	505	505	505
Fresh food capacity gross litres	334		334	334	334	334	334	334	334	334
Fresh food capacity net litres	325		325	325	325	325	325	325	325	325
Freezer capacity gross litres	206		206	206	206	206	206	206	206	206
Freezer capacity net litres	180		180	180	180	180	180	180	180	180
Total shelf area (cu.ft)		22.2								
Energy class	A+	A	A+	A+	A+	A+	A+	A+	A+	A+
Freezing In Capacity	12	12	12	12	12	12	12	12	12	12
Star rating of freezer	4	4	4	4	4	4	4	4	4	4
Voltage/hertz	50	50	50	50	50	50	50	50	50	50
Noise db(A)	45	44	45	45	45	45	45	45	45	45
Energy consumption (kWh)	438	547	438	438	438	438	438	438	438	438
Multi - flow	•		•	•	•	•	•	•	•	•
Extra Features										
Anti-bacterial Microban® protection	•		•	•	•	•	•	•	•	•
Fully frost free	•		•	•	•	•	•	•	•	•
Freezer shelves	•	n/a	•	•	•	•	•	•	•	•
Fridge shelves	•	drawer	•	•	•	•	•	•	•	•
Fridge shelves glass spinguard	•		•	•	•	•	•	•	•	•
Humidity controlled crisper drawer	•		•	•	•	•	•	•	•	•
Adjustable zero degree meat container	•		•	•	•	•	•	•	•	•
Chef's pantry	•		•	•	•	•	•	•	•	•
Refrigerator lights	•		•	•	•	•	•	•	•	•
Black out alert	•		•	•	•	•	•	•	•	•
Freezer lights	•		•	•	•	•	•	•	•	•
Fitted panel kit for 6mm panels	•		•	•	•	•	•	•	•	•
Power cut safe time (hrs)	5	7	5	5	5	5	5	5	5	5

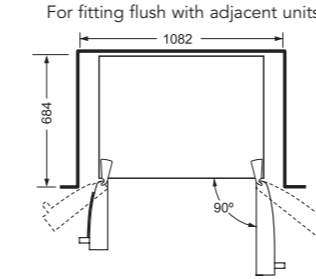
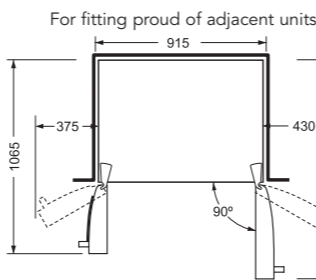
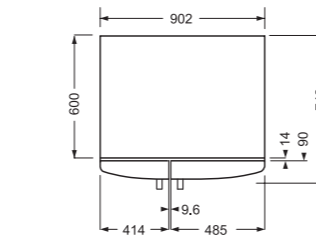
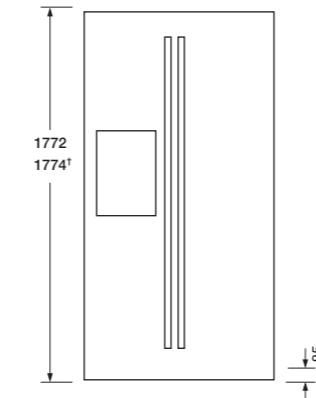

MSS 20 FISI4/MSS 20 FSSI3/
MSS 20 FBBI4/MSS 20 FBBI3

Contact Maytag for the panel dimensions.

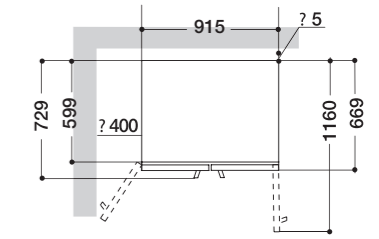
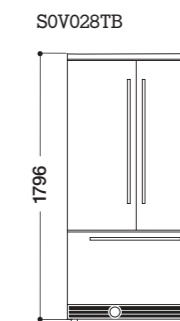
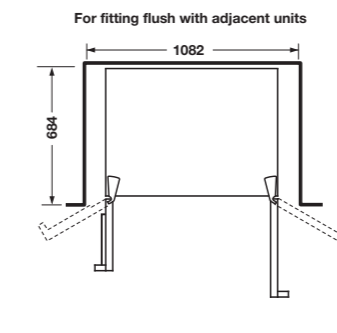
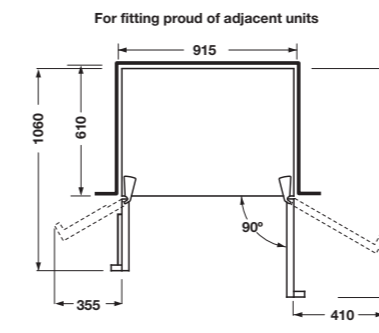
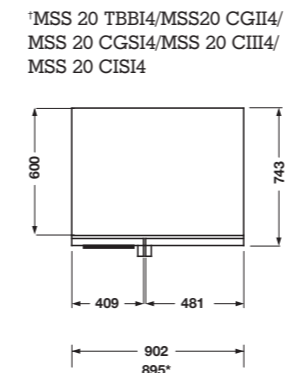

¹IEC standard testing

SPECIFICATIONS